



národní
úložiště
šedé
literatury

Change in Size-Resolved Filtration Efficiency of Respirators after Decontamination/Disinfection Treatments

Ondráček, Jakub
2022

Dostupný z <http://www.nusl.cz/ntk/nusl-510669>

Dílo je chráněno podle autorského zákona č. 121/2000 Sb.

Tento dokument byl stažen z Národního úložiště šedé literatury (NUŠL).

Datum stažení: 21.06.2024

Další dokumenty můžete najít prostřednictvím vyhledávacího rozhraní nusl.cz .

CHANGE IN SIZE-RESOLVED FILTRATION EFFICIENCY OF RESPIRATORS AFTER DECONTAMINATION/DISINFECTION TREATMENTS

Jakub ONDRÁČEK¹, Lucie ONDRÁČKOVÁ¹, Michal DŘEVÍNEK², Petr OTÁHAL², Josef VOŠÁHLÍK²

¹Department of Aerosol Chemistry and Physics, ICPF of the CAS, Prague, Czech Republic, ondracek@icpf.cas.cz

²Nuclear Protection Department, NINCBP, Kamenná, Czech Republic

Keywords: Respirators, size-resolved FE, decontamination, MPPS, pressure drop

INTRODUCTION

The COVID pandemic increased the global interest in high quality respirators or generally any Personal Protective Equipment (PPE) of respiratory tract. In order to assess the quality of the used PPE it is important to know the filtration efficiency (FE) and pressure drop (breathing resistance) of the PPEs.

Currently used filtration efficiency standards, such as EN149, were not developed to test the PPE FE against particles in sizes of viruses (i.e. < 200 nm). On top of this, the result of EN149 standard filtration efficiency testing is a single number, which could be described as an average filtration efficiency of the tested PPE over large size range of potentially dangerous aerosol particles. The penetration of these particles through the filtration material is a function of their size. Unfortunately, the size of “naked” SARS-CoV-2 virus particles (i.e. 80-150 nm) is in the size range, where the main physical mechanisms have very small effect on particle deposition inside the filtration material. Therefore, it is important to know ideally the size-resolved filtration efficiency of the PPE in order to obtain the information about the real protection efficiency of the PPE against the relevant dimensions of the dangerous particles. Such measurement also allows to find the size of the particles penetrating with the highest percentage through the material of PPE (MPPS), which is a crucial parameter to estimate the protection level of the PPE against specific agents, including e.g. SARS-CoV-2 virus particles.

Furthermore, during COVID pandemic many people were using the PPEs for longer time than it was suggested by the manufacturer or tried to use home-made or web community recommended decontamination/disinfection/antiviral treatments. Such treatments may severely destroy the structure of the filtration material and alter the filtration properties as compared to the original piece of the PPE and thus not protect the wearer properly against harmful particles. This work aims to estimate the change in the size-resolved filtration efficiency of different respirators after application of selected decontamination/disinfection treatments.

EXPERIMENTAL SETUP

The size resolved penetration through the material of PPEs (circular sample) was measured using filter testing system developed at LACP ICPF CAS. The simplified schematics of measurement apparatus can be seen on Fig. 1. The measurement was conducted with the flow rate of 8.7 l/min, corresponding to face velocity of 10.6 cm/s

across the sample of the material with active diameter 42 mm given by filter holder geometry. This face velocity is derived from a required flow rate of 95 l/min (according to EN149 standard) through the recommended cross-section of a respirator (facemask) of 150 cm². The challenging aerosol was generated by a nebulizer (AGK-2000, Palas) by dispersion of salt solution of (NH₄)₂SO₄ having concentration of 1 g/l. The generated aerosol was dried in the diffusion drier containing silica-gel, after that the Boltzmann charge distribution on aerosol particles was achieved by passing through a neutralizer with ⁸⁵Kr and then the treated aerosol continued into an electrostatic classifier (Electrostatic Classifier, EC Goliath, Research Workshop of ICPF CAS). The monodisperse fraction of the generated aerosol, selected in the classifier by corresponding voltage on the inner electrode, was diluted in the mixing volume so, that the required flow rate through the tested sample was reached. The number concentration of aerosol particles of given size was determined at the same time upstream and downstream the tested filtration material by two CPCs (Condensation Particle Counter).

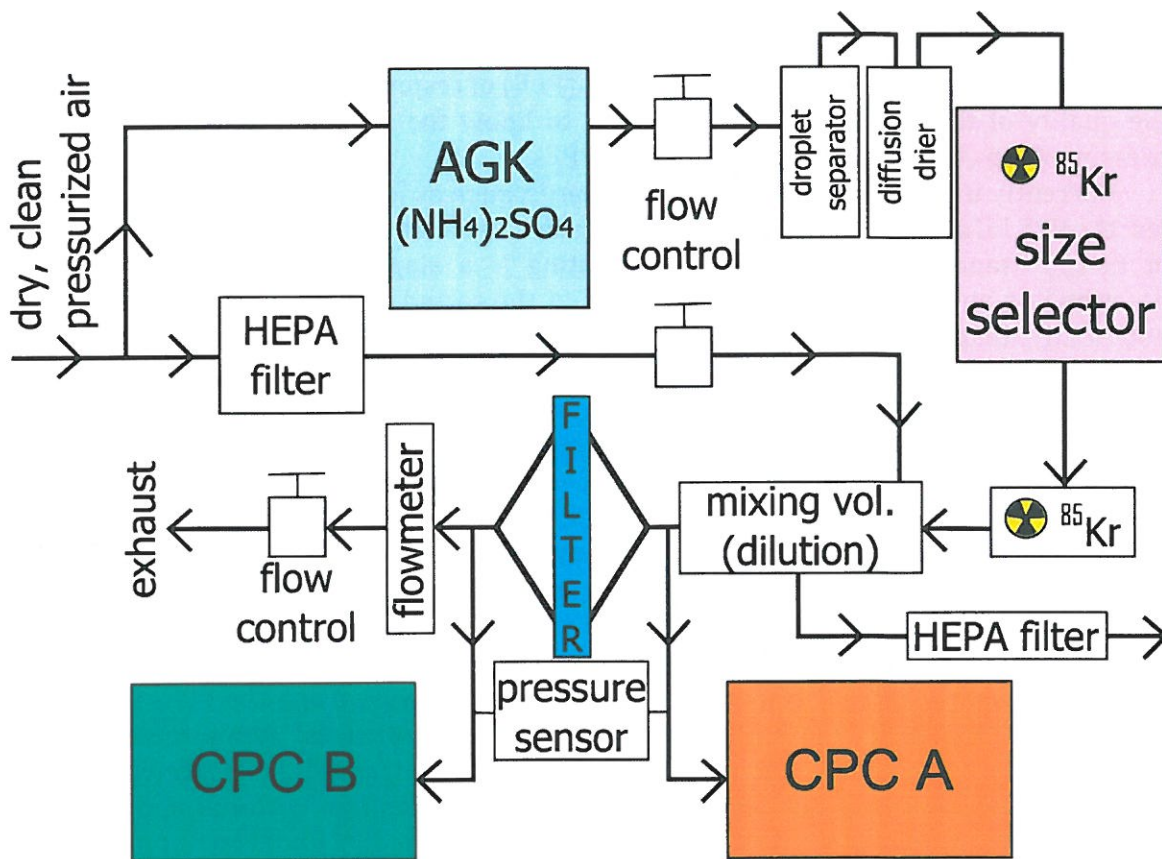

Fig. 1: Schematics of measurement set-up.

The position of the two CPCs was alternated for every selected size of the particles using the pair of electromagnetic valves. The valve switching allows avoiding any errors in measurement due to possible differences in the measurement of both counters. The changes in filtration material properties during the measurement (e.g. filter loading by challenging aerosol) were monitored by the measurement of pressure drop across the filter.

This approach has several advantages as compared to EN149 standard. It has to be considered that the EN 149 standard uses polydisperse aerosol and the method itself is

different from our approach. Moreover, the EN 149 is burdened with many artifacts, which are in most of the cases overestimating the filtration efficiency, and is not very suitable for judging the efficiency of the filtration materials against particles in the sizes from tenths to hundreds of nanometers (the size of SARS-CoV-2 particles was estimated to vary between 80 to 150 nm).

The EN 149 standard uses as a challenge aerosol so called polydisperse aerosol (mixture of sodium chloride particles covering the particle size range 20 nm – 2 µm with mass median diameter at 600 nm and corresponding count median diameter at 360 nm). In most of the cases, the modern filtration materials are having very good filtration efficiency at 360 nm, which is the size of the highest concentration of the challenging aerosol according to EN 149. However, the real MPPS of these materials is usually bellow 100 nm. Furthermore, the detection method giving the information about particle concentration in EN 149 is size dependent – i.e. the larger particles (hundreds of nanometers to units of micrometers) give much more intense signal and these particles are removed by the material with very high efficiency, therefore the resulting filtration efficiency is distorted towards higher numbers.

Several different types of respirator were chosen for the measurements in order to cover a part of the commonly used respirators available on the market (Tab. 1).

Tab. 1: List of tested respirator types.

Type (Name)	Manufacturer	EN 149 class
ADD Air Active 5500	Air Active	FFP3 NR
G&W GDGP3	Guandong Tengsheng	FFP3 NR
General Public Protection	General Public	FFP3 NR
PHARMAWEX Ro1	PHARMAWEX	FFP2 NR
Refil 750	Refil	FFP3 NR
SpurTex V100	SPUR	FFP2 NR

Tab. 2: List of applied decontamination/disinfection treatments.

Abbreviation	Decontamination treatment	Repetitions
T1	Thermal	1x
T3	dry heat 70°C	3x
T10	60 min	10x
E1	Ethanol	1x
E3	75% bath	3x
E10	15 min	10x
CH1	Chlorine based	1x
CH3	0.6% NaClO bath	3x
CH10	30 min	10x
PV1	Peroxyacetic acid	1x
PV3	saturated vapours	3x
PV10	atmosphere	10x

The decontamination/disinfection treatments were selected to cover part of available approaches (Tab. 2). The treatments were repeated once, 3 and 10 times to see the effect of repeated procedure on the size-resolved filtration efficiency of the respirator materials.

RESULTS AND CONCLUSIONS

Most of the small changes in FE after different decontamination/disinfection treatments is most probably caused rather by the differences in the filtration efficiency of the original material – piece to piece variability in filtration material quality (see Fig.2). Most of the PPEs originally meet their declared EN149 class (checking @CMD=360 nm, which should correspond to MMAD=600 nm according to EN149). And all the materials have MPPS < 100 nm.

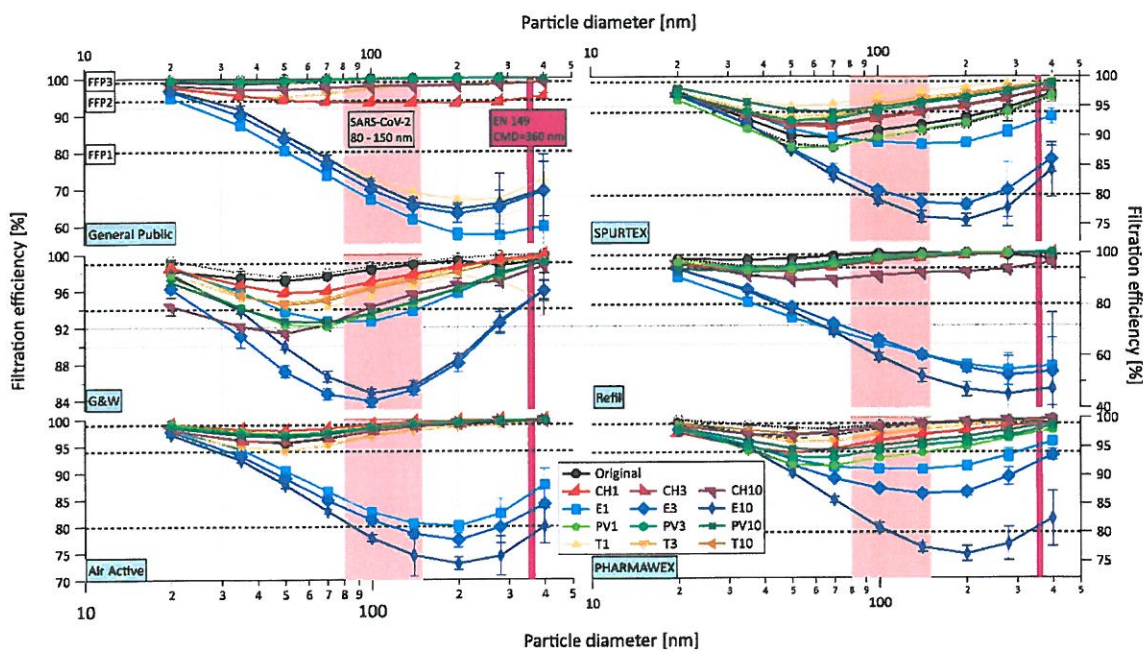

Fig. 2: Size-resolved filtration efficiency for different PPEs after application of various decontamination/disinfection treatments.

However, some more pronounced negative effects can be seen after applying the ethanol bath (for all the respirator types). This effect can be twofold. The removal of the electrostatic charge, originally enhancing the filtration efficiency of the PPE material, by the application of liquid can be one reason for lowered filtration efficiency. The other negative effect can be partial destruction of the structure of filtration material by ethanol (i.e. dissolution of the glues or other damage caused by the interaction of ethanol with the filtration material).

ACKNOWLEDGEMENT

This work was supported by the Ministry of Interior of the Czech Republic under the project no. VI04000048.